

THIS DRAWING IS UNPUBLISHED. RELEASED FOR PUBLICATION
 © COPYRIGHT BY TYCO ELECTRONICS CORPORATION. ALL RIGHTS RESERVED.

LOC	DIST	REVISIONS					
AJ	00	P	LTR	DESCRIPTION	DATE	DWN	APVD
			T1	REV PER ECO 06-027516	1/17/2007	DW	JL

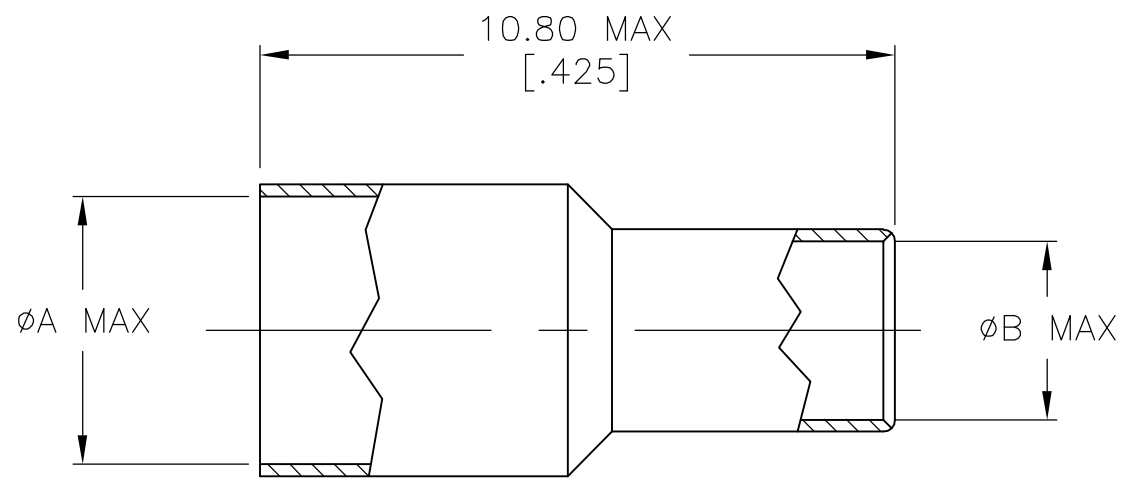

- ① SILVER PLATE PER QQ-S-365
5.08 μm [.000200] MINIMUM THICK.
- ② TIN-LEAD PLATE PER ASTM-B-545
2.54 μm [.000100] MINIMUM THICK,
WITH SUPPLEMENTAL ANTI FRETTING
LUBRICANT.
- ③ GOLD PLATE PER MIL-G-45204
0.76 μm [.000030] MINIMUM THICK.
- ④ MATTE TIN PLATE PER ASTM-B-545
2.54 μm [.000100] MINIMUM THICK,
WITH SUPPLEMENTAL ANTI FRETTING
LUBRICANT.

3.05 [.120]	3.86 [.152]	①	9-328666-3	
3.73 [.147]	4.55 [.179]	④	9-328666-2	
3.05 [.120]	3.86 [.152]	④	9-328666-1	
3.05 [.120]	4.55 [.179]	④	9-328666-0	
3.40 [.134]	4.55 [.179]	②	3-328666-9	
5.03 [.198]	5.51 [.217]	②	3-328666-6	
3.73 [.147]	4.55 [.179]	②	3-328666-3	
3.05 [.120]	3.86 [.152]	②	2-328666-7	
3.05 [.120]	4.55 [.179]	③	2-328666-6	
3.05 [.120]	4.55 [.179]	②	2-328666-5	
3.05 [.120]	4.55 [.179]	①	2-328666-3	
3.05 [.120]	3.86 [.152]	①	328666	
B		A	FINISH	PART NUMBER

THIS DRAWING IS A CONTROLLED DOCUMENT.		DWN J. LIPPERT 28MAR01	Tyco Electronics Corporation Harrisburg, PA 17105-3608	
DIMENSIONS: mm [INCHES]		CHK R.E.RUTH 7/27/90		
TOLERANCES UNLESS OTHERWISE SPECIFIED:		APVD M. SNEED 7/27/90	NAME	
0 PLC ± - 1 PLC ± - 2 PLC ± - 3 PLC ± - 4 PLC ± - ANGLES ± -		PRODUCT SPEC	FERRULE	
MATERIAL COPPER: QQ-C-576		FINISH SEE TABLE	APPLICATION SPEC	RESTRICTED TO
		WEIGHT -	SIZE A3	CAGE CODE 00779
		CUSTOMER DRAWING	DRAWING NO C-328666	RESTRICTED TO -
		SCALE 1:1	SHEET 1 OF 1	REV T1